

INPcom. EXTENSIÓN COMUNICACIÓN CON EPA SWMM 5.0e y EPANET 2.0e

DELIMITACIÓN DE RESPONSABILIDADES:

La presente extensión de comunicación ha sido desarrollada por www.tecnicsassociats.com. Aunque se ha hecho un esfuerzo por testear y validar el código, este está aún en fase experimental. Por consiguiente ni el autor ni sus colaboradores se hacen responsables, ni asumen ninguna relación con cualquiera de los resultados obtenidos, ni del uso que se haga de los mismos, ni tampoco de los daños o litigios que resultaran de la utilización de esta código para cualquier fin.

1. FICHA TÉCNICA DE LA VERSIÓN

Versión de INPcom:	1.7.2 (Evolución de versión 1.4 en el apartado EPA SWMM 5.0e.)
Versión de gvSIG:	1.11
Versiones de EPA:	SWMM 5.0e. EPANET 2.0e.
Características:	Exportación a EPA SWMM 5.0e de cualquier dato disponible en gvSIG. Exportación a EPANET 2.0e de datos geométricos de red.
Idioma de la interface de usuario:	Castellano / Català / English
Idiomas modelo datos EPA SWMM	Nombre tablas en inglés y campos en castellano. Explicación de campos en inglés.

2. INSTALACIÓN

Copiar directorio com.tecnicsassociats.gvsig.inp_com en la carpeta extensiones ubicada en la ruta donde se halle instalado gvSIG (...bin\gvSIG\extensiones).

3. USO

Para exportar, en primer lugar hay que poner la información en un único directorio, al que vamos a llamar directorio de exportación. La información que debe contener este directorio de exportación será ajustada a las especificaciones requeridas, tanto para EPA SWMM como para EPANET. Estas especificaciones reflejan los datos que puede ser exportados (EPA SWMM 5.0e en su totalidad, EPANET solo geometrías de red) y en las mismas se detalla también título, nombres y formatos de campos que son necesarios en los DBF's correspondientes.

Es necesario que en ambas redes el sentido de digitalización coincida con el sentido de determinado en los nodos. Se recomienda además, crear las redes en base a una topología ARCO-NODO y con la información de campos completada. Una vez llegado a este punto, se puede proceder a la selección de entidades por comportamiento hidráulico, exportando cada una de las selecciones al DBF correspondiente.

Casos específicos de las capas SUBCATH y VERTICE:

Para VERTICE –información geométrica de los vértices de giro en geometrías arco- es necesario crear la capa para poderla editar y completar. Aunque **INPcom** sólo lee la información almacenada en el DBF, se aconseja ubicar en el directorio de exportación todos los archivos asociados al 'Shape file'.

La información almacenada en SUBCATCH –información geométrica de polígonos de drenaje, caso específico para EPA SWMM- es la única que debe ser ubicada en su totalidad en el directorio de exportación. Esto significa que todos los archivos que forman parte del 'Shape file' deben ubicarse en el dicho directorio puesto que **INPcom** realiza la lectura de la información geométrica de los polígonos de drenaje en los archivos de contenido geométrico.

Llegados a este punto, se debe ejecutar la extensión en el menú de gvSIG, sin necesidad de cargar las capas y los DBF's en gvSIG.

En este sentido, solo hay que escoger a que programa quiere exportarse, indicar el directorio donde guardar el archivo generado y finalmente indicar el nombre del archivo (con extensión INP).

Para EPA SWMM existe la posibilidad de inhabilitar la exportación de geometrías de cuencas (solo datos de geometrías visuales). En caso de un número elevado de cuencas, esta opción puede ser interesante puesto que acelera y estabiliza el proceso de exportación.

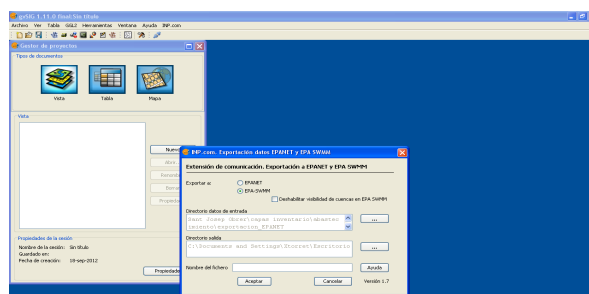

*Nota técnica: Mientras **INPcom** no resuelva la importación de información a gvSIG, se puede retornar con datos y resultados generados importando el(los) fichero(s) de texto desde un editor de hojas de cálculo como por ejemplo Libreoffice, para exportar después a DBF la información necesaria.*

SANEAMIENTO Y DRENAJE URBANO. MODELO DE DATOS COMPATIBLE CON INP com v1.7.2

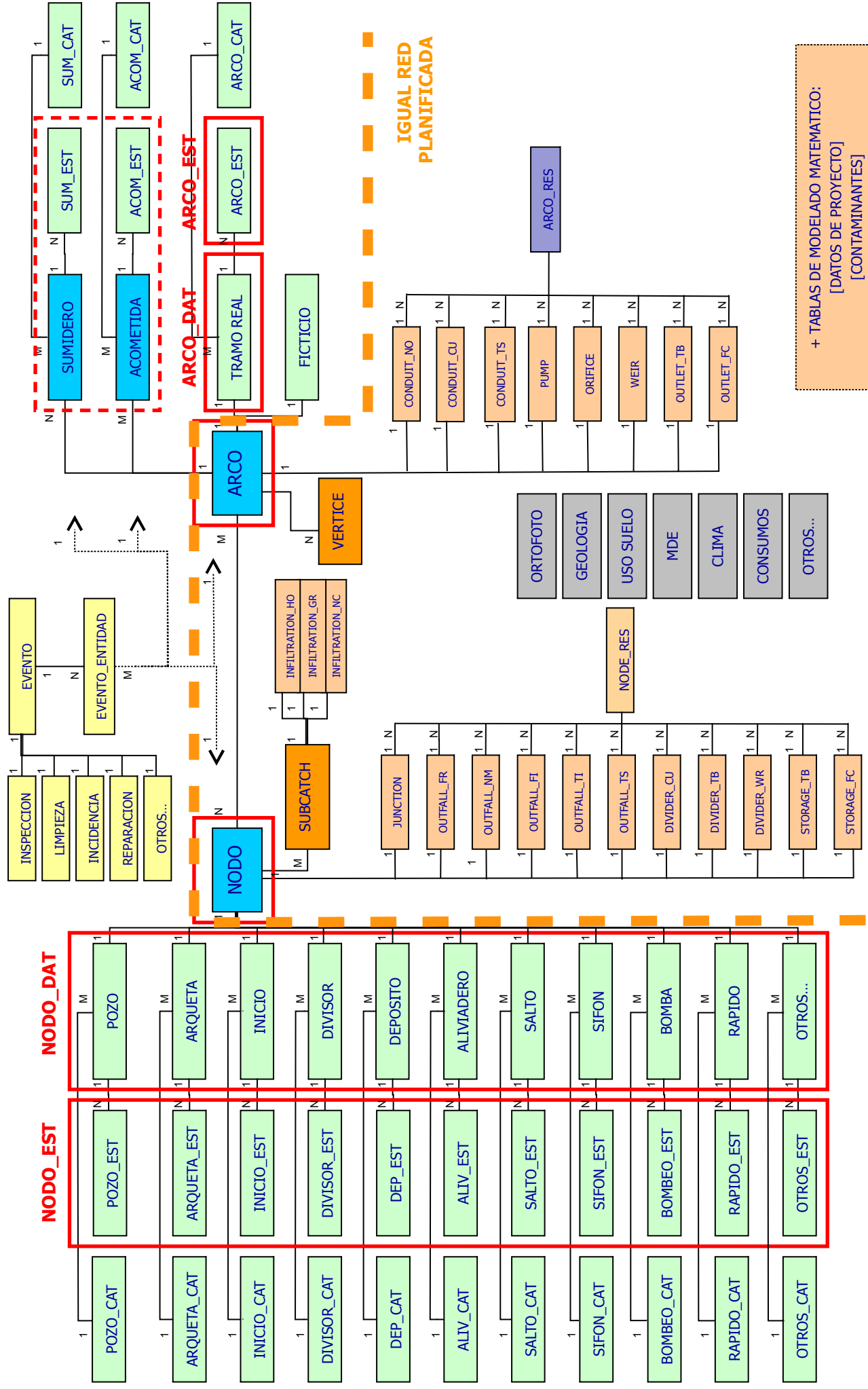

ESPECIFICACIONES MODELO DE DATOS EXTENSIÓN COMUNICACIÓN INPcom v1.7.2 (EPA SWMM)

PROJECT_ID

ES_ID	TIPO	LONGITUD	EN DESCRIPCIÓN
ID	INTEGER	2	ID number (1, 2, 3 ...)
TITULO	STRING	254	Project title
AUTOR	STRING	50	Name of project's author
FECHA	STRING	12	Date

OPTIONS

ES_ID	TIPO	LONGITUD	EN DESCRIPCIÓN
ID	INTEGER	2	ID number (1, 2, 3 ...)
PARAMETRO	STRING	20	Options parameters of SWMM project
VALOR	STRING	20	Options value parameters of SWMM project

BACKDROP

ES_ID	TIPO	LONGITUD	EN DESCRIPCIÓN
ID	INTEGER	2	ID number (1, 2, 3 ...)
COLUMN_1	STRING	10	Values in column 1. See the SWMM's Manual
COLUMN_2	STRING	254	Values in column 2. See the SWMM's Manual
COLUMN_3	STRING	12	Values in column 3. See the SWMM's Manual
COLUMN_4	STRING	12	Values in column 4. See the SWMM's Manual
COLUMN_5	STRING	12	Values in column 5. See the SWMM's Manual

LABELS

ES_ID	TIPO	LONGITUD	EN DESCRIPCIÓN
ID	INTEGER	2	ID number (1, 2, 3 ...)
ID_LABEL	STRING	16	Text of label surrounded by double quotes
XCOORD	DOUBLE		Horizontal coordinate relative to origin in lower left of map
YCOORD	DOUBLE		Vertical coordinate relative to origin in lower left of map
ANCLAJE	STRING	16	Name of node or subcatchment that anchors the label on zoom-ins (use an empty pair of double quotes if there is no anchor)
FUENTE	STRING	50	Name of label's font (surround by double quotes if the font name includes spaces)
TAM_FUENTE	DOUBLE		Font size in points
NEGRITA	STRING	3	YES for bold font, NO otherwise
CURSIVA	STRING	3	YES for italic font, NO otherwise

REPORT

ES_ID	TIPO	LONGITUD	EN DESCRIPCIÓN
ID	STRING	2	ID number (1, 2, 3 ...)
PARAMETRO	STRING	20	Report parameters of SWMM project
VALOR	STRING	20	Report value parameters of SWMM project

FILES

ES_ID	TIPO	LONGITUD	EN DESCRIPCIÓN
ID	INTEGER	8	ID number (1, 2, 3 ...)
ACCION	STRING	10	USE / SAVE
PARAMETRO	STRING	10	RAINFALL, RUNOFF, HOTSTART, RDII or ROUTING
FICHERO	STRING	254	Name of file

EVAP_CO

ES_ID	TIPO	LONGITUD	EN DESCRIPCIÓN
ID	INTEGER	8	ID number (1, 2, 3 ...)
TIPO_EVAP	STRING	12	Evaporation type (see the SWMM's Manual)
VALOR	DOUBLE		Evaporation value parameters of SWMM project

ESPECIFICACIONES MODELO DE DATOS EXTENSIÓN COMUNICACIÓN INPcom v1.7.2 (EPA SWMM)

EVAP_MO

ES_ID	TIPO	LONGITUD	EN DESCRIPCIÓN
ID	INTEGER	8	ID number (1, 2, 3 ...)
TIPO_EVAP	STRING	12	Evaporation type (see the SWMM's Manual)
VALOR_1	DOUBLE		Evaporation value parameters of SWMM project
VALOR_2	DOUBLE		Evaporation value parameters of SWMM project
VALOR_3	DOUBLE		Evaporation value parameters of SWMM project
VALOR_4	DOUBLE		Evaporation value parameters of SWMM project
VALOR_5	DOUBLE		Evaporation value parameters of SWMM project
VALOR_6	DOUBLE		Evaporation value parameters of SWMM project
VALOR_7	DOUBLE		Evaporation value parameters of SWMM project
VALOR_8	DOUBLE		Evaporation value parameters of SWMM project
VALOR_9	DOUBLE		Evaporation value parameters of SWMM project
VALOR_10	DOUBLE		Evaporation value parameters of SWMM project
VALOR_11	DOUBLE		Evaporation value parameters of SWMM project
VALOR_12	DOUBLE		Evaporation value parameters of SWMM project

EVAP_TS

ES_ID	TIPO	LONGITUD	EN DESCRIPCIÓN
ID	INTEGER	8	ID number (1, 2, 3 ...)
TIPO_EVAP	STRING	12	Evaporation type (see the SWMM's Manual)
ID_TIMESER	STRING	16	Specifies that evaporation data will come from a time series located in the [TIMESERIES] section of the input file.

EVAP_FL

ES_ID	TIPO	LONGITUD	EN DESCRIPCIÓN
ID	INTEGER	8	ID number (1, 2, 3 ...)
TIPO_EVAP	STRING	12	Evaporation type (see the SWMM's Manual)
FICHERO	STRING	254	Name of file
ID_EST	STRING	16	Precipitation station number
FECHA_INI	STRING	12	Date to begin reading from the file in Month-Day-Year format
FECHA_FIN	STRING	12	Date to end reading from the file in Month-Day-Year format

EVAP_PA

ES_ID	TIPO	LONGITUD	EN DESCRIPCIÓN
ID	INTEGER	8	ID number (1, 2, 3 ...)
TIPO_EVAP	STRING	12	Evaporation type (see the SWMM's Manual)
VALOR_1	DOUBLE		Evaporation value parameters of SWMM project
VALOR_2	DOUBLE		Evaporation value parameters of SWMM project
VALOR_3	DOUBLE		Evaporation value parameters of SWMM project
VALOR_4	DOUBLE		Evaporation value parameters of SWMM project
VALOR_5	DOUBLE		Evaporation value parameters of SWMM project
VALOR_6	DOUBLE		Evaporation value parameters of SWMM project
VALOR_7	DOUBLE		Evaporation value parameters of SWMM project
VALOR_8	DOUBLE		Evaporation value parameters of SWMM project
VALOR_9	DOUBLE		Evaporation value parameters of SWMM project
VALOR_10	DOUBLE		Evaporation value parameters of SWMM project
VALOR_11	DOUBLE		Evaporation value parameters of SWMM project
VALOR_12	DOUBLE		Evaporation value parameters of SWMM project

RGAGE_FL

ES_ID	TIPO	LONGITUD	EN DESCRIPCIÓN
ID	INTEGER	8	ID number (1, 2, 3 ...)
ID_PLUV	STRING	16	Name assigned to rain gage
TIPO_PLUV	STRING	12	FILE or TIMESERIES
FICHERO	STRING	50	Name of external file
ID_EST	STRING	16	Precipitation station number
FECHA_INI	STRING	12	Date to begin reading from the file in Month-Day-Year format
FECHA_FIN	STRING	12	Date to end reading from the file in Month-Day-Year format
XCOORD	DOUBLE		Horizontal coordinate of vertex relative to origin in lower left of map
YCOORD	DOUBLE		Vertical coordinate of vertex relative to origin in lower left of map

ESPECIFICACIONES MODELO DE DATOS EXTENSIÓN COMUNICACIÓN INPcom v1.7.2 (EPA SWMM)

RGAGE_TS

ES_ID	TIPO	LONGITUD	EN_DESCRIPCIÓN
ID	INTEGER	8	ID number (1, 2, 3 ...)
ID_PLUV	STRING	16	Name assigned to rain gage
TIPO_PLUV	STRING	12	FILE or TIMESERIES
ID_TIMESER	STRING	16	Name of time series
FORMATO	STRING	10	INTENSITY, VOLUME or CUMULATIVE
INTERVALO	STRING	12	Time interval between gage readings (in decimal hours or hours:minutes format)
XCOORD	DOUBLE		Horizontal coordinate of vertex relative to origin in lower left of map
YCOORD	DOUBLE		Vertical coordinate of vertex relative to origin in lower left of map

TEMP_MO

ES_ID	TIPO	LONGITUD	EN_DESCRIPCIÓN
ID	INTEGER	8	ID number (1, 2, 3 ...)
TIPO_TEMP	STRING	12	Evaporation type (see the SWMM's Manual)
VALOR_1	DOUBLE		Temperature value parameters of SWMM project
VALOR_2	DOUBLE		Temperature value parameters of SWMM project
VALOR_3	DOUBLE		Temperature value parameters of SWMM project
VALOR_4	DOUBLE		Temperature value parameters of SWMM project
VALOR_5	DOUBLE		Temperature value parameters of SWMM project
VALOR_6	DOUBLE		Temperature value parameters of SWMM project
VALOR_7	DOUBLE		Temperature value parameters of SWMM project
VALOR_8	DOUBLE		Temperature value parameters of SWMM project
VALOR_9	DOUBLE		Temperature value parameters of SWMM project
VALOR_10	DOUBLE		Temperature value parameters of SWMM project
VALOR_11	DOUBLE		Temperature value parameters of SWMM project
VALOR_12	DOUBLE		Temperature value parameters of SWMM project

TEMP_TS

ES_ID	TIPO	LONGITUD	EN_DESCRIPCIÓN
ID	INTEGER	8	ID number (1, 2, 3 ...)
TIPO_TEMP	STRING	12	Evaporation type (see the SWMM's Manual)
ID_TIMESER	STRING	16	Specifies that temperature data will come from a time series located in the [TIMESERIES] section of the input file.

TEMP_FL

ES_ID	TIPO	LONGITUD	EN_DESCRIPCIÓN
ID	INTEGER	8	ID number (1, 2, 3 ...)
TIPO_TEMP	STRING	12	Evaporation type (see the SWMM's Manual)
FICHERO	STRING	254	Name of file
ID_EST	STRING	16	8-digit NWS station number
MAX_MIN	DOUBLE		MAX for daily maximum values or MIN for minimum values
FECHA_INI	STRING	12	Date to begin reading from the file in Month-Day-Year format
FECHA_FIN	STRING	12	Date to end reading from the file in Month-Day-Year format

SUBCATCH

ES_ID	TIPO	LONGITUD	EN_DESCRIPCIÓN
ID	INTEGER	8	ID number (1, 2, 3 ...)
ID_NODO	STRING	16	Name of node assigned to subcatchment
ID_SUBC	STRING	16	Name assigned to subcatchment
ID_PLUV	STRING	16	Name of rain gage assigned to subcatchment
AREA_HA	DOUBLE		Area of subcatchment (acres or hectares)
IMPER	DOUBLE		Percent imperviousness of subcatchment
ANCHO	DOUBLE		Characteristic width of subcatchment (ft or meters)
PENDIENTE	DOUBLE		Subcatchment slope (percent)
N_IMP	DOUBLE		Manning's N for overland flow over the impervious sub-area
N_PER	DOUBLE		Manning's N for overland flow over the pervious sub-area
AL_IMP	DOUBLE		Depression storage for impervious sub-area (inches or mm)
AL_PER	DOUBLE		Depression storage for pervious sub-area (inches or mm)
A_IMP_DEP	DOUBLE		Percent of impervious area with no depression storage
FLUJO	STRING	10	Use IMPERV if pervious area runoff runs onto impervious area, PERV if impervious runoff runs onto impervious area, or OUTLET if both areas drain to the subcatchment's outlet.
CLONGITUD	DOUBLE		Total curb length (any length units)

ESPECIFICACIONES MODELO DE DATOS EXTENSIÓN COMUNICACIÓN INPcom v1.7.2 (EPA SWMM)

INFILTRATION_HO

ES_ID	TIPO	LONGITUD	EN DESCRIPCIÓN
ID	INTEGER	8	ID number (1, 2, 3 ...)
ID_SUBC	STRING	16	Name assigned to subcatchment
MAX_TASA	DOUBLE		Maximum infiltration rate on Horton curve (in/hr or mm/hr)
MIN_TASA	DOUBLE		Minimum infiltration rate on Horton curve (in/hr or mm/hr)
C_DISMIN	DOUBLE		Decay rate of Horton curve (1/sec)
T_SEC	DOUBLE		Dry weather regeneration factor for Horton curve (fraction)
V_MAX	DOUBLE		Maximum infiltration volume possible (0 if not applicable) (in or mm)

INFILTRATION_GR

ES_ID	TIPO	LONGITUD	EN DESCRIPCIÓN
ID	INTEGER	8	ID number (1, 2, 3 ...)
ID_SUBC	STRING	16	Name assigned to subcatchment
ALT_SUCC	DOUBLE		Soil capillary suction (in or mm)
CONDUCT	DOUBLE		Soil saturated hydraulic conductivity (in/hr or mm/hr)
DEF_INI	DOUBLE		Initial soil moisture deficit (fraction)

INFILTRATION_NC

ES_ID	TIPO	LONGITUD	EN DESCRIPCIÓN
ID	INTEGER	8	ID number (1, 2, 3 ...)
ID_SUBC	STRING	16	Name assigned to subcatchment
NC	DOUBLE		Runoff Curve Number
CONDUCT	DOUBLE		Soil saturated hydraulic conductivity (in/hr or mm/hr)
T_SEC	DOUBLE		Dry weather regeneration constant (1/hr)

AQUIFERS

ES_ID	TIPO	LONGITUD	EN DESCRIPCIÓN
ID	INTEGER	8	ID number (1, 2, 3 ...)
ID_AQUIF	STRING	16	Aquifer name
POR	DOUBLE		Soil porosity (fraction)
WP	DOUBLE		Soil wilting point (fraction)
FC	DOUBLE		Soil field capacity (fraction)
K	DOUBLE		Saturated hydraulic conductivity (in/hr or mm/hr)
KPEND	DOUBLE		Slope of hydraulic conductivity versus moisture content curve
HPEND	DOUBLE		Slope of soil tension versus moisture content curve
UEF	DOUBLE		Fraction of total evaporation available for evapotranspiration in the upper unsaturated zone
LED	DOUBLE		Maximum depth into the lower saturated zone over which evapotranspiration can occur (ft or m)
GWM	DOUBLE		Rate of percolation from saturated zone to deep groundwater when water table is at ground surface (in/hr or mm/hr)
BE	DOUBLE		Elevation of the bottom of the aquifer (ft or m)
WTE	DOUBLE		Water table elevation at start of simulation (ft or m)
UMC	DOUBLE		Unsaturated zone moisture content at start of simulation (fraction)

GROUNDWATER

ES_ID	TIPO	LONGITUD	EN DESCRIPCIÓN
ID	INTEGER	8	ID number (1, 2, 3 ...)
ID_SUBC	STRING	16	Subcatchment name
ID_AQUIF	STRING	16	Name of groundwater aquifer underneath the subcatchment
ID_NODO	STRING	16	Name of node in conveyance system exchanging groundwater with aquifer
ELEV_SUP	DOUBLE		Surface elevation of subcatchment (ft or m)
A1	DOUBLE		Groundwater flow coefficient (see the SWMM's Manual)
B1	DOUBLE		Groundwater flow exponent (see the SWMM's Manual)
A2	DOUBLE		Surface water flow coefficient (see the SWMM's Manual)
B2	DOUBLE		Surface water flow exponent (see the SWMM's Manual)
A3	DOUBLE		Surface water – groundwater interaction coefficient (see the SWMM's Manual)
TW	DOUBLE		Fixed depth of surface water at receiving node (ft or m) (set to zero if surface water depth will vary as computed by flow routing)

SNOWMELT

ES_ID	TIPO	LONGITUD	EN DESCRIPCIÓN
-------	------	----------	----------------

ESPECIFICACIONES MODELO DE DATOS EXTENSIÓN COMUNICACIÓN INPcom v1.7.2 (EPA SWMM)

JUNCTION

ES_ID	TIPO	LONGITUD	EN DESCRIPCIÓN
ID	INTEGER	8	ID number (1, 2, 3 ...)
ID_NODO	STRING	16	Name assigned to junction node
COTA_INF	DOUBLE		Elevation of junction invert (ft or m)
PROF	DOUBLE		Depth from ground to invert elevation (ft or m)
PROF_INI	DOUBLE		Water depth at start of simulation (ft or m)
PRES_REG	DOUBLE		Maximum additional head above ground elevation that manhole junction can sustain under surcharge conditions (ft or m)
AREA_INUND	DOUBLE		Area subjected to surface ponding once water depth exceeds SurDepth (ft ² or m ²)
XCOORD	DOUBLE		Horizontal coordinate of vertex relative to origin in lower left of map
YCOORD	DOUBLE		Vertical coordinate of vertex relative to origin in lower left of map

OUTFALL_FR

ES_ID	TIPO	LONGITUD	EN DESCRIPCIÓN
ID	INTEGER	8	ID number (1, 2, 3 ...)
ID_NODO	STRING	16	Name assigned to outfall node
COTA_INF	DOUBLE		Invert elevation (ft or m)
XCOORD	DOUBLE		Horizontal coordinate of vertex relative to origin in lower left of map
YCOORD	DOUBLE		Vertical coordinate of vertex relative to origin in lower left of map
TIPO_OTF	STRING	12	FREE
COMPUERTA	STRING	3	YES or NO depending on whether a flap gate is present or not.

OUTFALL_NM

ES_ID	TIPO	LONGITUD	EN DESCRIPCIÓN
ID	INTEGER	8	ID number (1, 2, 3 ...)
ID_NODO	STRING	16	Name assigned to outfall node
COTA_INF	DOUBLE		Invert elevation (ft or m)
XCOORD	DOUBLE		Horizontal coordinate of vertex relative to origin in lower left of map
YCOORD	DOUBLE		Vertical coordinate of vertex relative to origin in lower left of map
TIPO_OTF	STRING	12	NORMAL
COMPUERTA	STRING	3	YES or NO depending on whether a flap gate is present or not.

OUTFALL_FI

ES_ID	TIPO	LONGITUD	EN DESCRIPCIÓN
ID	INTEGER	8	ID number (1, 2, 3 ...)
ID_NODO	STRING	16	Name assigned to outfall node
COTA_INF	DOUBLE		Invert elevation (ft or m)
XCOORD	DOUBLE		Horizontal coordinate of vertex relative to origin in lower left of map
YCOORD	DOUBLE		Vertical coordinate of vertex relative to origin in lower left of map
TIPO_OTF	STRING	12	FIXED
COTA_FIJA	DOUBLE		Elevation of fixed stage outfall (ft or m)
COMPUERTA	STRING	3	YES or NO depending on whether a flap gate is present or not.

OUTFALL_TI

ES_ID	TIPO	LONGITUD	EN DESCRIPCIÓN
ID	INTEGER	8	ID number (1, 2, 3 ...)
ID_NODO	STRING	16	Name assigned to outfall node
COTA_INF	DOUBLE		Invert elevation (ft or m)
XCOORD	DOUBLE		Horizontal coordinate of vertex relative to origin in lower left of map
YCOORD	DOUBLE		Vertical coordinate of vertex relative to origin in lower left of map
TIPO_OTF	STRING	12	TIDAL
ID_CURBA	STRING	16	Name of curve in [CURVES] section containing tidal height (i.e., outfall stage) v. hour of day over a complete tidal cycle
COMPUERTA	STRING	3	YES or NO depending on whether a flap gate is present or not.

ESPECIFICACIONES MODELO DE DATOS EXTENSIÓN COMUNICACIÓN INPcom v1.7.2 (EPA SWMM)

OUTFALL_TS

ES_ID	TIPO	LONGITUD	EN DESCRIPCIÓN
ID	INTEGER	8	ID number (1, 2, 3 ...)
ID_NODO	STRING	16	Name assigned to outfall node
COTA_INF	DOUBLE		Invert elevation (ft or m)
XCOORD	DOUBLE		Horizontal coordinate of vertex relative to origin in lower left of map
YCOORD	DOUBLE		Vertical coordinate of vertex relative to origin in lower left of map
TIPO_OTF	STRING	12	TIMESERIES
ID_TIMESER	STRING	16	Name of time series in [TIMESERIES] section that describes how outfall stage varies with time
COMPUERTA	STRING	3	YES or NO depending on whether a flap gate is present or not.

DIVIDER_CU

ES_ID	TIPO	LONGITUD	EN DESCRIPCIÓN
ID	INTEGER	8	ID number (1, 2, 3 ...)
ID_NODO	STRING	16	Name assigned to divider node
COTA_INF	DOUBLE		Invert elevation (ft or m)
XCOORD	DOUBLE		Horizontal coordinate of vertex relative to origin in lower left of map
YCOORD	DOUBLE		Vertical coordinate of vertex relative to origin in lower left of map
TIPO_DIV	STRING	12	CUTOFF
ID_ARCO	STRING	16	Name of arc to which flow is diverted
CAUDAL_NOM	DOUBLE		Flow for CUTOFF divider at which diversion begins (flow units)

DIVIDER_TB

ES_ID	TIPO	LONGITUD	EN DESCRIPCIÓN
ID	INTEGER	8	ID number (1, 2, 3 ...)
ID_NODO	STRING	16	Name assigned to divider node
COTA_INF	DOUBLE		Invert elevation (ft or m)
XCOORD	DOUBLE		Horizontal coordinate of vertex relative to origin in lower left of map
YCOORD	DOUBLE		Vertical coordinate of vertex relative to origin in lower left of map
TIPO_DIV	STRING	12	TABULAR
ID_ARCO	STRING	16	Name of arc to which flow is diverted
ID_CURBA	STRING	16	Name of curve in [CURVES] that relates diverted flow to total flow

DIVIDER_WR

ES_ID	TIPO	LONGITUD	EN DESCRIPCIÓN
ID	INTEGER	8	ID number (1, 2, 3 ...)
ID_NODO	STRING	16	Name assigned to divider node
COTA_INF	DOUBLE		Invert elevation (ft or m)
XCOORD	DOUBLE		Horizontal coordinate of vertex relative to origin in lower left of map
YCOORD	DOUBLE		Vertical coordinate of vertex relative to origin in lower left of map
TIPO_DIV	STRING	12	WEIR
ID_ARCO	STRING	16	Name of arc to which flow is diverted
MIN_CAUDAL	DOUBLE		Minimum flow for WEIR divider (flow units)
MAX_CAUDAL	DOUBLE		Maximum flow for WEIR divider (flow units)
MAX_ALT	DOUBLE		Maximum head difference over WEIR divider (ft or m)
CD	DOUBLE		Discharge coefficient for WEIR divider

STORAGE_TB

ES_ID	TIPO	LONGITUD	EN DESCRIPCIÓN
ID	INTEGER	8	ID number (1, 2, 3 ...)
ID_NODO	STRING	16	Name assigned to storage node
COTA_INF	DOUBLE		Invert elevation (ft or m)
PROF	DOUBLE		Maximum water depth possible (ft or m)
PROF_INI	DOUBLE		Water depth at start of simulation (ft or m)
XCOORD	DOUBLE		Horizontal coordinate of vertex relative to origin in lower left of map
YCOORD	DOUBLE		Vertical coordinate of vertex relative to origin in lower left of map
TIPO_DEP	STRING	12	TABULAR
ID_ARCO	STRING	16	Name of arc to which flow is diverted
ID_CURBA	STRING	16	Name of curve in [CURVES] with surface area (ft2 or m2) as a function of depth (ft or m) for TABULAR geometry

ESPECIFICACIONES MODELO DE DATOS EXTENSIÓN COMUNICACIÓN INPcom v1.7.2 (EPA SWMM)

STORAGE_FC

ES_ID	TIPO	LONGITUD	EN DESCRIPCIÓN
ID	INTEGER	8	ID number (1, 2, 3 ...)
ID_NODO	STRING	16	Name assigned to storage node
COTA_INF	DOUBLE		Invert elevation (ft or m)
PROF	DOUBLE		Maximum water depth possible (ft or m)
PROF_INI	DOUBLE		Water depth at start of simulation (ft or m)
XCOORD	DOUBLE		Horizontal coordinate of vertex relative to origin in lower left of map
YCOORD	DOUBLE		Vertical coordinate of vertex relative to origin in lower left of map
TIPO_DEP	STRING	12	FUNCTIONAL
ID_ARCO	STRING	16	Name of arc to which flow is diverted
ACOEFF	DOUBLE		Coefficient of power function that relates surface area A (ft ² or m ²) to depth D (ft or m) for FUNCTIONAL geometry (i.e., $A = Acoeff(D)Aexp$)
AEXP	DOUBLE		Exponent of power function that relates surface area A (ft ² or m ²) to depth D (ft or m) for FUNCTIONAL geometry (i.e., $A = Acoeff(D)Aexp$)

CONDUIT_NO

ES_ID	TIPO	LONGITUD	EN DESCRIPCIÓN
ID	INTEGER	8	ID number (1, 2, 3 ...)
ID_ARCO	STRING	16	Name assigned to conduit link
NODO_INI	STRING	16	Name of upstream node
NODO_FIN	STRING	16	Name of downstream node
LONGITUD	DOUBLE		Conduit length (ft or m)
MAINING	DOUBLE		Value of N (i.e., roughness parameter) in Manning's equation
SALTO_INI	DOUBLE		Offset height of upstream end of conduit invert above the invert elevation of its upstream node (ft or m)
SALTO_FIN	DOUBLE		Offset height of downstream end of conduit invert above the invert elevation of its downstream node (ft or m)
CAUDAL_INI	DOUBLE		Flow in conduit at start of simulation (flow units)
FORMA_TUB	STRING	16	Cross-section shape (see Table 2 below for available shapes of SWMM's Manual)
GEOM1	DOUBLE		Maximum depth (ft or m)
GEOM2	DOUBLE		Width parameter (ft or m)
GEOM3	DOUBLE		Auxiliary parameters (e.g., side slopes) (See Table 2 for details of SWMM's Manual)
GEOM4	DOUBLE		Auxiliary parameters (e.g., side slopes) (See Table 2 for details of SWMM's Manual)
UNIDADES	DOUBLE		Number of barrels (i.e., number of parallel pipes of equal size, slope, and roughness) associated with a conduit (default is 1)

CONDUIT_CU

ES_ID	TIPO	LONGITUD	EN DESCRIPCIÓN
ID	INTEGER	8	ID number (1, 2, 3 ...)
ID_ARCO	STRING	16	Name assigned to conduit link
NODO_INI	STRING	16	Name of upstream node
NODO_FIN	STRING	16	Name of downstream node
LONGITUD	DOUBLE		Conduit length (ft or m)
MAINING	DOUBLE		Value of N (i.e., roughness parameter) in Manning's equation
SALTO_INI	DOUBLE		Offset height of upstream end of conduit invert above the invert elevation of its upstream node (ft or m)
SALTO_FIN	DOUBLE		Offset height of downstream end of conduit invert above the invert elevation of its downstream node (ft or m)
CAUDAL_INI	DOUBLE		Flow in conduit at start of simulation (flow units)
FORMA_TUB	STRING	16	Cross-section shape (see Table 2 below for available shapes of SWMM's Manual)
GEOM1	DOUBLE		Maximum depth (ft or m)
ID_CURBA	STRING	16	Name of a Shape Curve in the [CURVES] section that defines how width varies with depth
GEOM2	DOUBLE		Width parameter (no geom2 for custom)
GEOM3	DOUBLE		Auxiliary parameters (e.g., side slopes, no geom3 for custom)
UNIDADES	DOUBLE		Number of barrels (i.e., number of parallel pipes of equal size, slope, and roughness) associated with a conduit (default is 1)

ESPECIFICACIONES MODELO DE DATOS EXTENSIÓN COMUNICACIÓN INPcom v1.7.2 (EPA SWMM)

CONDUIT_TS

ES_ID	TIPO	LONGITUD	EN DESCRIPCIÓN
ID	INTEGER	8	ID number (1, 2, 3 ...)
ID_ARCO	STRING	16	Name assigned to conduit link
NODO_INI	STRING	16	Name of upstream node
NODO_FIN	STRING	16	Name of downstream node
LONGITUD	DOUBLE		Conduit length (ft or m)
MAINING	DOUBLE		Value of N (i.e., roughness parameter) in Manning's equation
SALTO_INI	DOUBLE		Offset height of upstream end of conduit invert above the invert elevation of its upstream node (ft or m)
SALTO_FIN	DOUBLE		Offset height of downstream end of conduit invert above the invert elevation of its downstream node (ft or m)
CAUDAL_INI	DOUBLE		Flow in conduit at start of simulation (flow units)
FORMA_TUB	STRING	16	Cross-section shape (see Table 2 below for available shapes of SWMM's Manual)
ID_TSECT	STRING	16	Name of an entry in the [TRANSECTS] section that describes the crosssection geometry of an irregular channel

PUMP

ES_ID	TIPO	LONGITUD	EN DESCRIPCIÓN
ID	INTEGER	8	ID number (1, 2, 3 ...)
ID_ARCO	STRING	16	Name assigned to conduit link
NODO_INI	STRING	16	Name of upstream node
NODO_FIN	STRING	16	Name of downstream node
TIPO_BOM	STRING	12	TYPE1, TYPE2, TYPE3, or TYPE4
ID_CURBA	STRING	16	Name of pump curve listed in the [TABLES] section of the input
EST_INI	STRING	3	Either ON or OFF

ORIFICE

ES_ID	TIPO	LONGITUD	EN DESCRIPCIÓN
ID	INTEGER	8	ID number (1, 2, 3 ...)
ID_ARCO	STRING	16	Name assigned to conduit link
NODO_INI	STRING	16	Name of upstream node
NODO_FIN	STRING	16	Name of downstream node
TIPO_ORI	STRING	12	SIDE or BOTTOM
ALTURA	DOUBLE		Height of a side orifice's bottom from invert of upstream node (ft or m)
FORMA	STRING	16	The only allowable shapes are CIRCULAR and RECT_CLOSED (closed rectangular)
GEOM1	DOUBLE		Maximum depth (ft or m)
GEOM2	DOUBLE		Width parameter (ft or m)
CD	DOUBLE		Discharge coefficient (unitless)
COMPUERTA	STRING	3	YES if flap gate present, NO if not

WEIR

ES_ID	TIPO	LONGITUD	EN DESCRIPCIÓN
ID	INTEGER	8	ID number (1, 2, 3 ...)
ID_ARCO	STRING	16	Name assigned to conduit link
NODO_INI	STRING	16	Name of upstream node
NODO_FIN	STRING	16	Name of downstream node
TIPO_ALIV	STRING	12	TRANSVERSE, SIDEFLOW, V-NOTCH, or TRAPEZOIDAL
ALTURA	DOUBLE		Height of weir crest above invert of upstream node (ft or m)
FORMA	STRING	16	See Table of page number 250 of SWMM's Manual
GEOM1	DOUBLE		Maximum depth (ft or m)
GEOM2	DOUBLE		Width parameter (ft or m)
CD	DOUBLE		Weir discharge coefficient (for CFS if using US flow units or CMS if using metric flow units)
EC	DOUBLE		Number of end contractions for TRANSVERSE or TRAPEZOIDAL weir
CD2	DOUBLE		Discharge coefficient for triangular ends of a TRAPEZOIDAL weir (for CFS if using US flow units or CMS if using metric flow units)

ESPECIFICACIONES MODELO DE DATOS EXTENSIÓN COMUNICACIÓN INPcom v1.7.2 (EPA SWMM)

OUTLET_TB

ES_ID	TIPO	LONGITUD	EN DESCRIPCIÓN
ID	INTEGER	8	ID number (1, 2, 3 ...)
ID_ARCO	STRING	16	Name assigned to conduit link
NODO_INI	STRING	16	Name of upstream node
NODO_FIN	STRING	16	Name of downstream node
TIPO_OTL	STRING	12	TABULAR/HEAD o TABULAR/DEPTH
ALTURA	DOUBLE		Minimum water depth at upstream node for outflow to occur (ft or m)
ID_CURBA	STRING	16	Name of rating curve with outflow rate (flow units) as a function of head (ft or m) across the outlet for a TABULAR outlet
COMPUERTA	STRING	3	YES if flap gate present, NO if not

OUTLET_FC

ES_ID	TIPO	LONGITUD	EN DESCRIPCIÓN
ID	INTEGER	8	ID number (1, 2, 3 ...)
ID_ARCO	STRING	16	Name assigned to conduit link
NODO_INI	STRING	16	Name of upstream node
NODO_FIN	STRING	16	Name of downstream node
TIPO_OTL	STRING	12	FUNCTIONAL/HEAD o FUNCTIONA/DEPTH
ALTURA	DOUBLE		Minimum water depth at upstream node for outflow to occur (ft or m)
QCOEFF	DOUBLE		Coefficient of power function that relates outflow (Q) to head across the outlet (H) for a FUNCTIONAL outlet (i.e., $Q = Q_{coeff}(H)^{Q_{exp}}$)
QEXPON	DOUBLE		Exponent of power function that relates outflow (Q) to head across the outlet (H) for a FUNCTIONAL outlet (i.e., $Q = Q_{coeff}(H)^{Q_{exp}}$)
COMPUERTA	STRING	3	YES if flap gate present, NO if not

TRANSECTS

ES_ID	TIPO	LONGITUD	EN DESCRIPCIÓN
ID	INTEGER	8	ID number (1, 2, 3 ...)
TEXTO	STRING	254	See SWMM manual

LOSSES

ES_ID	TIPO	LONGITUD	EN DESCRIPCIÓN
ID	INTEGER	8	ID number (1, 2, 3 ...)
ID_ARCO	STRING	16	Name of conduit
PERD_INI	DOUBLE		Entrance minor loss coefficient
PERD_FIN	DOUBLE		Exit minor loss coefficient
POR_PERD	DOUBLE		Average minor loss coefficient across length of conduit
COMPUERTA	STRING	3	YES if conduit has a flap gate that prevents back flow, NO otherwise

CONTROLS

ES_ID	TIPO	LONGITUD	EN DESCRIPCIÓN
ID	INTEGER	8	ID number (1, 2, 3 ...)
TEXTO	STRING	254	Controls rules

POLLUTANTS

ES_ID	TIPO	LONGITUD	EN DESCRIPCIÓN
ID	INTEGER	8	ID number (1, 2, 3 ...)
ID_CONT	STRING	16	Name assigned to pollutant
UNIDADES	STRING	4	Concentration units (MG/L for milligrams per liter, UG/L for micrograms per liter, or #/L for direct count per liter)
CON_LLUV	DOUBLE		Concentration of pollutant in rainfall (concentration units)
CON_SUB	DOUBLE		Concentration of pollutant in groundwater (concentration units)
KDECA	DOUBLE		First-order decay coefficient (1/days)
ID_COCONT	STRING	16	Name of co-pollutant
POR_COCON	DOUBLE		Fraction of co-pollutant concentration

ESPECIFICACIONES MODELO DE DATOS EXTENSIÓN COMUNICACIÓN INPcom v1.7.2 (EPA SWMM)

LANDUSES

ES_ID	TIPO	LONGITUD	EN DESCRIPCIÓN
ID	INTEGER	8	ID number (1, 2, 3 ...)
ID_USO	STRING	16	Land use name
DIAS_INT	INTEGER	4	Days between street sweeping
POR_CONT	DOUBLE		Fraction of pollutant buildup available for removal by street sweeping
DIAS_PREV	INTEGER	4	Days since last sweeping at start of the simulation

COVERAGES

ES_ID	TIPO	LONGITUD	EN DESCRIPCIÓN
ID	INTEGER	8	ID number (1, 2, 3 ...)
ID_SUBC	STRING	16	Subcatchment name
ID_USO	STRING	16	Land use name
PORCENT	DOUBLE		Percent of subcatchment area

BUILDUP

ES_ID	TIPO	LONGITUD	EN DESCRIPCIÓN
ID	INTEGER	8	ID number (1, 2, 3 ...)
ID_USO	STRING	16	Land use name
ID_CONT	STRING	16	Pollutant name
TIPO_FUN	STRING	12	Buildup function type: (POWER / EXPONENTIAL / SATURATION)
C1	DOUBLE		Buildup function parameters (see Table 3 of SWMM's Manual)
C2	DOUBLE		Buildup function parameters (see Table 3 of SWMM's Manual)
C3	DOUBLE		Buildup function parameters (see Table 3 of SWMM's Manual)
NORMALIT	STRING	10	AREA if buildup is per unit area, CURBLENGTH if per length of curb.

WASHOFF

ES_ID	TIPO	LONGITUD	EN DESCRIPCIÓN
ID	INTEGER	8	ID number (1, 2, 3 ...)
ID_USO	STRING	16	Land use name
ID_CONT	STRING	16	Pollutant name
TIPO_FUN	STRING	12	Buildup function type: (POWER / EXPONENTIAL / SATURATION)
COEFF	DOUBLE		Washoff model coefficient
EXPON	DOUBLE		Washoff model exponent
LIMP_EFI	DOUBLE		Street sweeping removal efficiency (percent)
BMP_EFI	DOUBLE		BMP removal efficiency (percent)

TREATMENT

ES_ID	TIPO	LONGITUD	EN DESCRIPCIÓN
-------	------	----------	----------------

LOADINGS

ES_ID	TIPO	LONGITUD	EN DESCRIPCIÓN
ID	INTEGER	8	ID number (1, 2, 3 ...)
ID_SUBC	STRING	16	Name of a subcatchment
ID_CONT	STRING	16	Name of a pollutant
INICIAL	DOUBLE		Initial buildup of pollutant (same units as used in [BUILDUP] section)

DWF

ES_ID	TIPO	LONGITUD	EN DESCRIPCIÓN
ID	INTEGER	8	ID number (1, 2, 3 ...)
ID_NODO	STRING	16	Name of node where dry weather flow enters
ITEM	STRING	16	Keyword FLOW for flow or pollutant name for quality constituent
VALOR	DOUBLE		Average baseline value for corresponding Item (flow or concentration units)
ID_PATMO	STRING	16	Optional name of time pattern appearing in the [PATTERNS] section
ID_PATDL	STRING	16	Optional name of time pattern appearing in the [PATTERNS] section
ID_PATAM	STRING	16	Optional name of time pattern appearing in the [PATTERNS] section
ID_PATPM	STRING	16	Optional name of time pattern appearing in the [PATTERNS] section
ID_PATAW	STRING	16	Optional name of time pattern appearing in the [PATTERNS] section
ID_PATPW	STRING	16	Optional name of time pattern appearing in the [PATTERNS] section

ESPECIFICACIONES MODELO DE DATOS EXTENSIÓN COMUNICACIÓN INPcom v1.7.2 (EPA SWMM)

PATTERNS_MO

ES_ID	TIPO	LONGITUD	EN_DESCRIPCIÓN
ID	INTEGER	8	ID number (1, 2, 3 ...)
ID_PATMO	STRING	16	Name used to identify the pattern
TIPO_PAT	STRING	12	MONTHLY
FACTOR_1	DOUBLE		Multiplier values
FACTOR_2	DOUBLE		Multiplier values
FACTOR_3	DOUBLE		Multiplier values
FACTOR_4	DOUBLE		Multiplier values
FACTOR_5	DOUBLE		Multiplier values
FACTOR_6	DOUBLE		Multiplier values
FACTOR_7	DOUBLE		Multiplier values
FACTOR_8	DOUBLE		Multiplier values
FACTOR_9	DOUBLE		Multiplier values
FACTOR_10	DOUBLE		Multiplier values
FACTOR_11	DOUBLE		Multiplier values
FACTOR_12	DOUBLE		Multiplier values

PATTERNS_DL

ES_ID	TIPO	LONGITUD	EN_DESCRIPCIÓN
ID	INTEGER	8	ID number (1, 2, 3 ...)
ID_PATDL	STRING	16	Name used to identify the pattern
TIPO_PAT	STRING	12	DAILY
FACTOR_1	DOUBLE		Multiplier values
FACTOR_2	DOUBLE		Multiplier values
FACTOR_3	DOUBLE		Multiplier values
FACTOR_4	DOUBLE		Multiplier values
FACTOR_5	DOUBLE		Multiplier values
FACTOR_6	DOUBLE		Multiplier values
FACTOR_7	DOUBLE		Multiplier values

PATTERNS_AM

ES_ID	TIPO	LONGITUD	EN_DESCRIPCIÓN
ID	INTEGER	8	ID number (1, 2, 3 ...)
ID_PATAM	STRING	16	Name used to identify the pattern
TIPO_PAT	STRING	12	AM
FACTOR_1	DOUBLE		Multiplier values
FACTOR_2	DOUBLE		Multiplier values
FACTOR_3	DOUBLE		Multiplier values
FACTOR_4	DOUBLE		Multiplier values
FACTOR_5	DOUBLE		Multiplier values
FACTOR_6	DOUBLE		Multiplier values
FACTOR_7	DOUBLE		Multiplier values
FACTOR_8	DOUBLE		Multiplier values
FACTOR_9	DOUBLE		Multiplier values
FACTOR_10	DOUBLE		Multiplier values
FACTOR_11	DOUBLE		Multiplier values
FACTOR_12	DOUBLE		Multiplier values

ESPECIFICACIONES MODELO DE DATOS EXTENSIÓN COMUNICACIÓN INPcom v1.7.2 (EPA SWMM)

PATTERNS_PM

ES_ID	TIPO	LONGITUD	EN DESCRIPCIÓN
ID	INTEGER	8	ID number (1, 2, 3 ...)
ID_PATPM	STRING	16	Name used to identify the pattern
TIPO_PAT	STRING	12	PM
FACTOR_1	DOUBLE		Multiplier values
FACTOR_2	DOUBLE		Multiplier values
FACTOR_3	DOUBLE		Multiplier values
FACTOR_4	DOUBLE		Multiplier values
FACTOR_5	DOUBLE		Multiplier values
FACTOR_6	DOUBLE		Multiplier values
FACTOR_7	DOUBLE		Multiplier values
FACTOR_8	DOUBLE		Multiplier values
FACTOR_9	DOUBLE		Multiplier values
FACTOR_10	DOUBLE		Multiplier values
FACTOR_11	DOUBLE		Multiplier values
FACTOR_12	DOUBLE		Multiplier values

PATTERNS_AMWE

ES_ID	TIPO	LONGITUD	EN DESCRIPCIÓN
ID	INTEGER	8	ID number (1, 2, 3 ...)
ID_PATAW	STRING	16	Name used to identify the pattern
TIPO_PAT	STRING	12	AM_WEEKEND
FACTOR_1	DOUBLE		Multiplier values
FACTOR_2	DOUBLE		Multiplier values
FACTOR_3	DOUBLE		Multiplier values
FACTOR_4	DOUBLE		Multiplier values
FACTOR_5	DOUBLE		Multiplier values
FACTOR_6	DOUBLE		Multiplier values
FACTOR_7	DOUBLE		Multiplier values
FACTOR_8	DOUBLE		Multiplier values
FACTOR_9	DOUBLE		Multiplier values
FACTOR_10	DOUBLE		Multiplier values
FACTOR_11	DOUBLE		Multiplier values
FACTOR_12	DOUBLE		Multiplier values

PATTERNS_PMWE

ES_ID	TIPO	LONGITUD	EN DESCRIPCIÓN
ID	INTEGER	8	ID number (1, 2, 3 ...)
ID_PATPW	STRING	16	Name used to identify the pattern
TIPO_PAT	STRING	12	PM_WEEKEND
FACTOR_1	DOUBLE		Multiplier values
FACTOR_2	DOUBLE		Multiplier values
FACTOR_3	DOUBLE		Multiplier values
FACTOR_4	DOUBLE		Multiplier values
FACTOR_5	DOUBLE		Multiplier values
FACTOR_6	DOUBLE		Multiplier values
FACTOR_7	DOUBLE		Multiplier values
FACTOR_8	DOUBLE		Multiplier values
FACTOR_9	DOUBLE		Multiplier values
FACTOR_10	DOUBLE		Multiplier values
FACTOR_11	DOUBLE		Multiplier values
FACTOR_12	DOUBLE		Multiplier values

INFLOWS_FLOW

ES_ID	TIPO	LONGITUD	EN DESCRIPCIÓN
ID	INTEGER	8	ID number (1, 2, 3 ...)
ID_NODO	STRING	16	Name of node where external inflow enters
TIPO_INF	STRING	12	FLOW
ID_TIMESER	STRING	16	Name of time series describing how external inflows vary with time

ESPECIFICACIONES MODELO DE DATOS EXTENSIÓN COMUNICACIÓN INPcom v1.7.2 (EPA SWMM)

INFLOWS_POLLUT

ES_ID	TIPO	LONGITUD	EN DESCRIPCIÓN
ID	INTEGER	8	ID number (1, 2, 3 ...)
ID_NODO	STRING	16	Name of node where external inflow enters
TIPO_INF	STRING	12	POLLUT
ID_TIMESER	STRING	16	Name of time series describing how external inflows vary with time
FORMATO	STRING	10	CONCEN if pollutant inflow is described as a concentration, MASS if it is described as a mass flow rate.
CONVERSION	DOUBLE		If pollutant inflow is a mass flow rate, the factor that converts this value into (concentration units) times (flow units), where concentration units are those specified for the pollutant in the [POLLUTANTS] section and flow units are those specified in the [OPTIONS] section

RDII

ES_ID	TIPO	LONGITUD	EN DESCRIPCIÓN
ID	INTEGER	8	ID number (1, 2, 3 ...)
ID_NODO	STRING	16	Name of a node
ID_HIDROG	STRING	16	Name of an RDII unit hydrograph group specified in the [HYDROGRAPHS] section
AREA	DOUBLE		Area of the sewershed which contributes RDII to the node (acres or hectares)

HYDROGRAPHS

ES_ID	TIPO	LONGITUD	EN DESCRIPCIÓN
ID	INTEGER	8	ID number (1, 2, 3 ...)
ID_HIDROG	STRING	16	Name assigned to a unit hydrograph (UH) group
COLUMN_2	STRING	16	Values in column 2
R1	DOUBLE		Response ratios for the short-term, intermediate-term, and long-term UH responses, respectively
T1	DOUBLE		Time to peak (hours) for the short-term, intermediate-term, and long-term UH responses, respectively
K1	DOUBLE		Recession limb ratios for short-term, intermediate-term, and long-term UH responses, respectively
R2	DOUBLE		Response ratios for the short-term, intermediate-term, and long-term UH responses, respectively
T2	DOUBLE		Time to peak (hours) for the short-term, intermediate-term, and long-term UH responses, respectively
K2	DOUBLE		Recession limb ratios for short-term, intermediate-term, and long-term UH responses, respectively
R3	DOUBLE		Response ratios for the short-term, intermediate-term, and long-term UH responses, respectively
T3	DOUBLE		Time to peak (hours) for the short-term, intermediate-term, and long-term UH responses, respectively
K3	DOUBLE		Recession limb ratios for short-term, intermediate-term, and long-term UH responses, respectively

CURVE

ES_ID	TIPO	LONGITUD	EN DESCRIPCIÓN
ID	INTEGER	8	ID number (1, 2, 3 ...)
ID_CURBA	STRING	16	Name assigned to table
TIPO_CURBA	STRING	12	STORAGE / DIVERSION / TIDAL / PUMP1 / PUMP2 / PUMP3 / PUMP4 / RATING
XVAL	DOUBLE		An x (independent variable) value
YVAL	DOUBLE		The y (dependent variable) value corresponding to x

TIMESERIES_ABS

ES_ID	TIPO	LONGITUD	EN DESCRIPCIÓN
ID	INTEGER	8	ID number (1, 2, 3 ...)
ID_TIMESER	STRING	16	Name assigned to time series
FECHA	STRING	12	Date in Month-Day-Year format (e.g., June 15, 2001 would be 6-15-2001)
HORA_ABS	STRING	10	24-hour military time (e.g., 8:40 pm would be 20:40) relative to the last date specified (or to midnight of the starting date of the simulation if no previous date was specified)
VALOR	DOUBLE		Value corresponding to given date and time

TIMESERIES_REL

ES_ID	TIPO	LONGITUD	EN DESCRIPCIÓN
ID	INTEGER	8	ID number (1, 2, 3 ...)
ID_TIMESER	STRING	16	Name assigned to time series
HORA_REL	STRING	10	hours since the start of the simulation, expressed as a decimal number or as Hours:Minutes
VALOR	DOUBLE		Value corresponding to given date and time

VERTICE

ES_ID	TIPO	LONGITUD	EN DESCRIPCIÓN
ID	INTEGER	8	ID number (1, 2, 3 ...)
ID_ARCO	STRING	16	Name assigned to conduit link
XCOORD	DOUBLE		Horizontal coordinate of vertex relative to origin in lower left of map
YCOORD	DOUBLE		Vertical coordinate of vertex relative to origin in lower left of map

ESPECIFICACIONES MODELO DE DATOS EXTENSIÓN COMUNICACIÓN INPcom v1.7.2 (EPANET)

JUNCTION

ES_ID	TIPO	LONGITUD	EN DESCRIPCIÓN
ID	INTEGER	8	ID number (1, 2, 3 ...)
ID_NODO	STRING	16	Name assigned to junction node
ALTURA	DOUBLE		Elevation of junction invert (ft or m)
XCOORD	DOUBLE		Horizontal coordinate of vertex relative to origin in lower left of map
YCOORD	DOUBLE		Vertical coordinate of vertex relative to origin in lower left of map

PIPE

ES_ID	TIPO	LONGITUD	EN DESCRIPCIÓN
ID	INTEGER	8	ID number (1, 2, 3 ...)
ID_ARCO	STRING	16	Name assigned to conduit link
NODO1	STRING	16	Name of first node
NODO2	STRING	16	Name of second node
LONGITUD	DOUBLE		Conduit length (ft or m)
DIAMETRO	DOUBLE		Maximum depth (ft or m)
RUGOSIDAD	DOUBLE		Roughness parameter)

VERTICE

ES_ID	TIPO	LONGITUD	EN DESCRIPCIÓN
ID	INTEGER	8	ID number (1, 2, 3 ...)
ID_ARCO	STRING	16	Name assigned to conduit link
XCOORD	DOUBLE		Horizontal coordinate of vertex relative to origin in lower left of map
YCOORD	DOUBLE		Vertical coordinate of vertex relative to origin in lower left of map